

STAINLESS STEEL TENSION GAS SPRING 6-18 SERIES FORCE RANGE 25 --400 NEWTON (5.5 to 88 LBS)

| Series 6-18 Tension Gas spring | Tension gas spring with valve | Stroke | Total length without attachments 2 x stroke + 67 mm | with Eyes, add 2 x 16 mm | With forks, add 2 x 20 mm | Swivel ends add 2 x 27 mm | Thread size Max. Newton Force |
|--------------------------------------|-------------------------------------|--------|---|-----------------------------|------------------------------|------------------------------|----------------------------------|
| 65.650 | Extended | 50 mm | 167 mm | 199 mm | 207 mm | 221 mm | M5 x 08 – 400N |
| | Compressed | 50 mm | 117 mm | 149 mm | 157 mm | 171 mm | M5 x 08 – 400N |
| 65.610 | Extended | 100 mm | 267 mm | 299 mm | 307 mm | 321 mm | M5 x 08 – 400N |
| | Compressed | 100 mm | 167 mm | 199 mm | 207 mm | 221 mm | M5 x 08 – 400N |
| 65.615 | Extended | 150 mm | 367 mm | 399 mm | 407 mm | 421 mm | M5 x 08 – 400N |
| | Compressed | 150 mm | 217 mm | 249 mm | 257 mm | 271 mm | M5 x 08 – 400N |
| 65.520 | Extended | 200 mm | 467 mm | 499 mm | 507 mm | 521 mm | M5 x 08 – 400N |
| | Compressed | 200 mm | 267 mm | 299 mm | 307 mm | 321 mm | M5 x 08 – 400N |

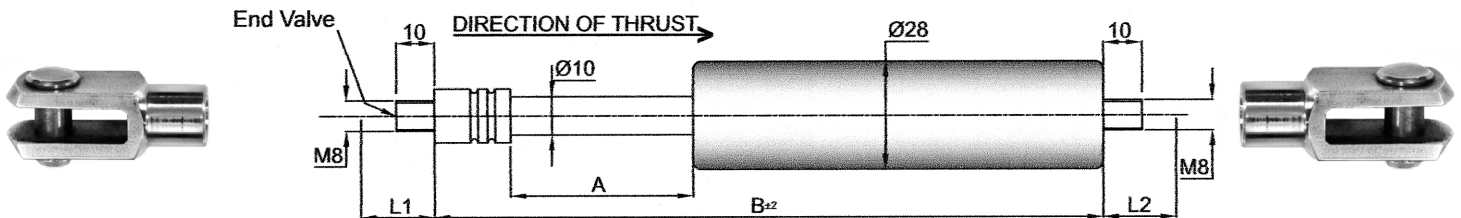

STAINLESS STEEL TENSION GAS SPRING 10-28 SERIES FORCE RANGE 50 --1250 NEWTON (11 to 275 LBS)

| Series 10-28 Tension Gas spring | Tension gas spring with valve | Stroke | Total length without attachments 2 x stroke + 107 mm | Small eyes, #62.819 add 2 x 19 mm | Big eyes, #62.827 add 2 x 27 mm | Forks, #62.833 (add 2 x 32 mm) | Thread size And Max Newton force |
|---------------------------------------|-------------------------------------|--------|--|---|---------------------------------------|--------------------------------------|--|
| 65.110 | Extended | 100mm | 307 mm | 345 mm | 361 mm | 371 mm | M8 x 1.25 – 1250N |
| | Compressed | 100 mm | 207 mm | 245 mm | 261 mm | 271 mm | M8 x 1.25 – 1250N |
| 65.115 | Extended | 150mm | 407 mm | 445 Mm | 461 mm | 471 mm | M8 x 1.25 – 1250N |
| | Compressed | 150 mm | 257 mm | 295 mm | 311 mm | 321 mm | M8 x 1.25 – 1250N |
| 65..120 | Extended | 200mm | 507 mm | 545 mm | 561 mm | 571 mm | M8 x 1.25 – 1250N |
| | Compressed | 200 mm | 307 mm | 345 mm | 361 mm | 371 mm | M8 x 1.25 – 1250N |
| 65.125 | Extended | 250mm | 607 mm | 645 mm | 661 mm | 671 mm | M8 x 1.25 – 1250N |
| | Compressed | 250 mm | 357 mm | 395 mm | 411 mm | 421 mm | M8 x 1.25 – 1250N |
| 65.130 | Extended | 300mm | 707 mm | 745 mm | 761 mm | 771 mm | M8 x 1.25 – 1250N |
| | Compressed | 300 mm | 407 mm | 445 mm | 461 mm | 471 mm | M8 x 1.25 – 1250N |
| 65.140 | Extended | 400mm | 907 mm | 945 mm | 961 mm | 971 mm | M8 x 1.25 – 1250N |
| | Compressed | 400 mm | 507 mm | 545 mm | 561 mm | 571 mm | M8 x 1.25 – 1250N |
| 65.150 | Extended | 500mm | 1107 mm | 445 mm | 1161 mm | 1171 mm | M8 x 1.25 – 1250N |
| | Compressed | 500 mm | 607 mm | 645 mm | 661 mm | 671 mm | M8 x 1.25 – 1250N |

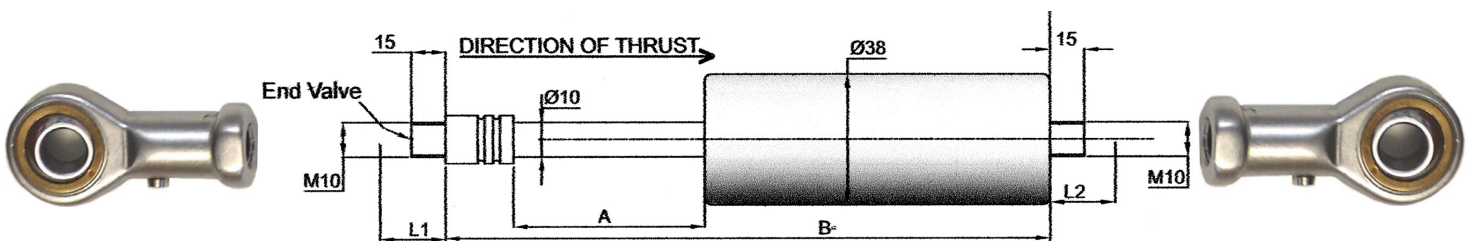

STAINLESS STEEL TENSION GAS SPRING 10-38 SERIES FORCE RANGE 100 --2500 NEWTON (22 to 550 LBS)

Available with Stroke from 50 mm to 1000 mm long. Add 121 mm to length of cylinder. Uses Size M10 #62.457 end fittings
Email our office at sales@izerwaren with your requirements for tensions gas springs.

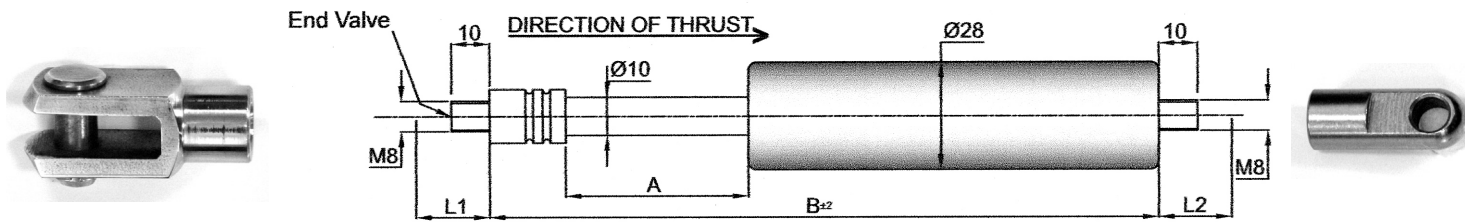
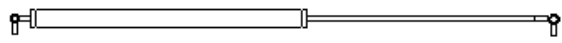

STAINLESS STEEL TENSION GAS SPRING 10-28 SERIES FORCE RANGE 50 --1250 NEWTON (11 to 275 LBS)

| Series 10-28 | Stainless steel tension gas spring with valve | Stroke | Total length without attachments (not counting the thread) (.. x stroke + 107 mm) | Total Length with <i>small</i> eyes, c. to c. hole; (add 2 x 19 mm) | Total Length with <i>big</i> eyes, c. to c. hole; (add 2 x 27 mm) | Total length with forks, c. to c. hole (add 2 x 32 mm) | Thread size |
|--------------|---|--------|---|---|---|--|-------------|
| 65.220 | Extended | 200mm | 507 mm | 545 mm | 561 mm | 571 mm | M8 |
| | Compressed | 200 mm | 307 mm | 345 mm | 361 mm | 371 mm | M8 |

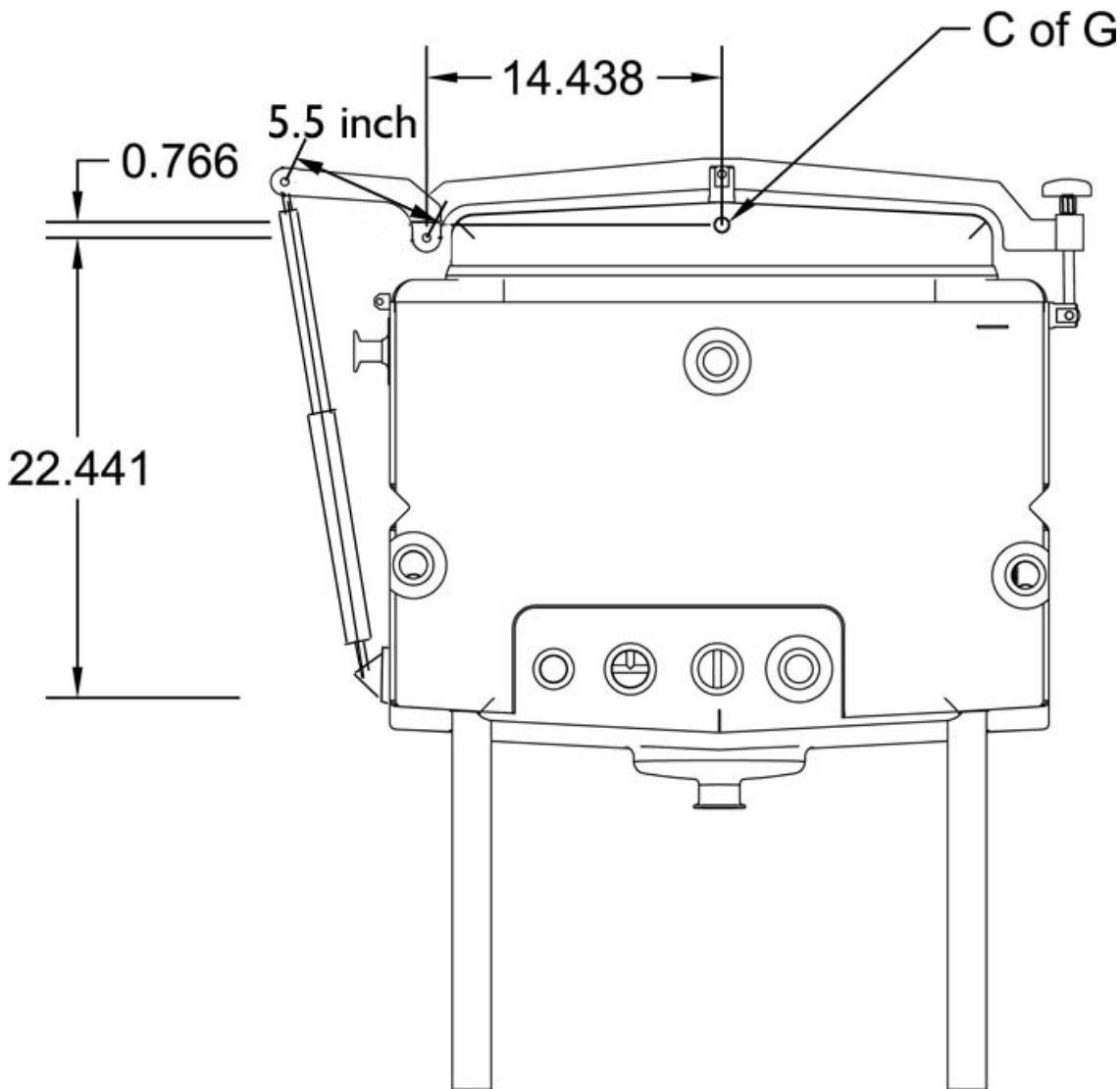

Sample Application Stainless Steel Tension Gas Spring

Note: Computer sketch not to scale

Proposed Solution: 2 Tension gas spring T10-28-200-307 with M8M8 thread
1023 Newton force each.

Container and Brackets on this page not for sale by Izerwaren Inc.